

High performance electric counterbalance truck with side battery access and 4th generation AC technology

Electric steering for improved operator comfort

New operating concept with SOLO- or MULTI-PILOT integrated in to the adjustable armrest

Automatic parking brake

Driver assistance systems (optional)

5 individually adjustable work programme



EFG 213–220

Three-wheel electric counterbalance truck (1300, 1500, 1600, 1800, 2000 kg)

The newest generation of AC technology offers numerous advantages for electric counterbalance trucks:

- Minimal energy consumption due to high efficiency and energy recovery.
- Minimal service costs due to the reduction of mechanical and hydraulic components.
- Efficient electric steering using AC technology.

The advantage: faster work cycles with significantly longer operating times from only one battery charge. Along with the reduced maintenance requirements, this results in low operating costs.

Changing the battery is simple and easy: the choice of three different battery changing options makes this easy for any user – even during three-shift operations.

The robust truck construction, user-friendly design and innovative technology ensures long term reliability.

- Robust construction with steel bumpers, steel bonnet and protected lights.
- Enclosed chassis – even under the battery – for added stability and protection.
- Maintenance-free components (e.g. brakes and transmission).
- Innovative technology with halogen bulbs and LEDs.

EFG 213–220

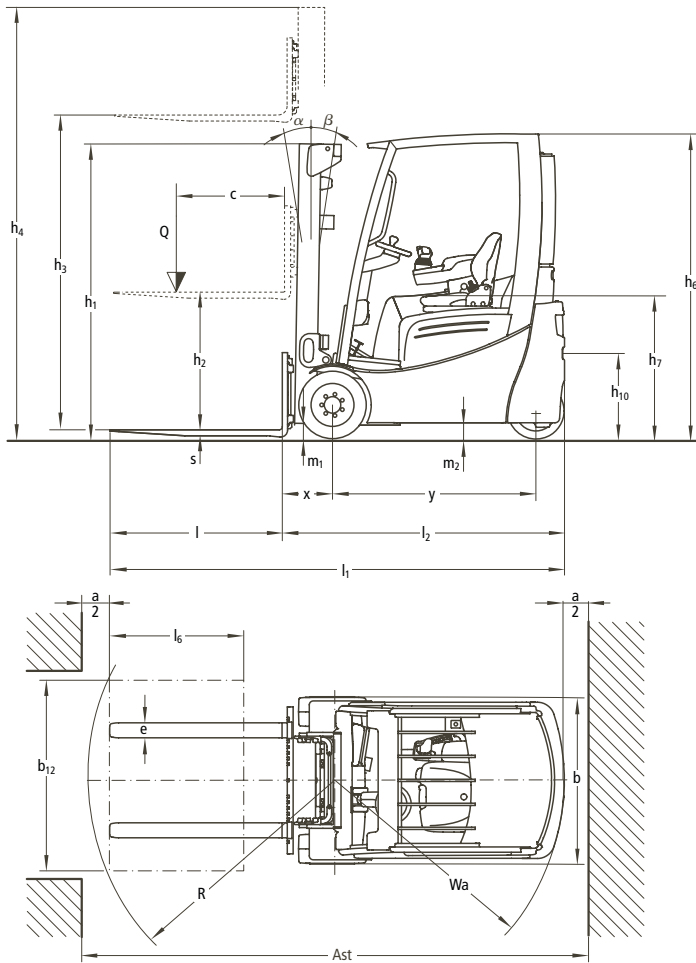

Capacity

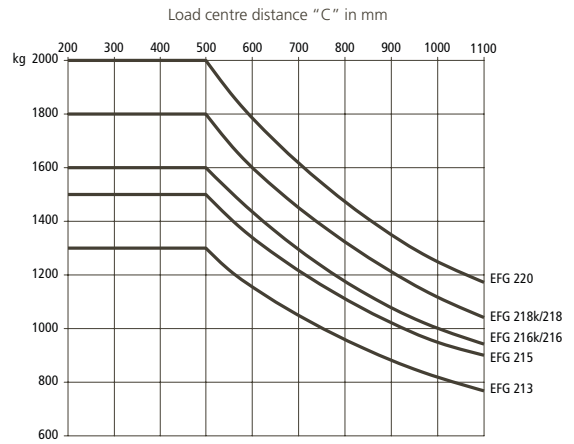

Designation	Lift height h_3 mm	Mast table EFG 213–220		Free lift h_2 mm	Closed height h_1 mm	Extended height h_4 (mm)		Tilt forward backward α/β (°)	Capacity table (kg) $c = 500$ mm				
		mm				mm			without sideshift, single solid tyres				
		EFG 213–216	EFG 218–220			EFG 213–216	EFG 218–220		EFG 213	EFG 215	EFG 216k/216	EFG 218k/218	EFG 220
Two-stage mast ZT	3000	150	150	2000	3550	3585	7°/7°	1300	1500	1600	1800	2000	
	3100	150	150	2050	3650	3685	7°/7°	1300	1500	1600	1800	2000	
	3300	150	150	2150	3850	3885	7°/7°	1300	1500	1600	1800	2000	
	3600	150	150	2300	4150	4185	7°/7°	1300	1500	1600	1800	2000	
	4000	150	150	2500	4550	4585	7°/7°	1300	1500	1600	1800	2000	
	4500	150	150	2800	5050	5085	7°/7°	1300	1500	1600	1800	2000	
Two-stage mast ZZ	3000	1405	1340	1955	3550	3615	7°/7°	1300	1500	1600	1800	2000	
	3100	1455	1390	2005	3650	3715	7°/7°	1300	1500	1600	1800	2000	
	3300	1555	1490	2105	3850	3915	7°/7°	1300	1500	1600	1800	2000	
	3600	1705	1640	2255	4150	4215	7°/7°	1300	1500	1600	1800	2000	
	4000	1905	1840	2455	4550	4615	7°/7°	1300	1500	1600	1800	2000	
Three-stage mast DZ	4500	1455	1390	2005	5050	5115	7°/7°	1300	1450	1600	1800	2000	
	4800	1555	1490	2105	5350	5415	7°/5°	1250	1400	1550	1700	1900	
	5000	1630	1565	2180	5550	5615	7°/5°	1200	1350	1500	1650	1800	
	5500	1805	1740	2355	6050	6115	7°/5°	1050	1250	1350	1500	1600	
	6000*	2005	1940	2555	6550	6615	7°/5°	900	–	1150	1300	1400	
	6500*	2255	2190	2805	7050	7115	7°/5°	750	–	950	1100	1150	

* Mast not available for EFG 215

Technical data in line with VDI 2198 as at: 08/2008

Identification	1.1	Manufacturer (abbreviation)	Jungheinrich	Jungheinrich	Jungheinrich	Jungheinrich	Jungheinrich	Jungheinrich	Jungheinrich	1.1	
	1.2	Manufacturer's type designation	EFG 213	EFG 215	EFG 216 k	EFG 216	EFG 218 k	EFG 218	EFG 220	1.2	
	1.3	Drive	electric	electric	electric	electric	electric	electric	electric	1.3	
	1.4	Operator type	seat	seat	seat	seat	seat	seat	seat	1.4	
	1.5	Load capacity/rated load Q (t)	1.3	1.5	1.6	1.6	1.8	1.8	2.0	1.5	
	1.6	Load centre distance c (mm)	500	500	500	500	500	500	500	1.6	
	1.8	Load distance, centre of drive axle to fork x (mm)	335 ¹⁾	335 ¹⁾	340 ²⁾	340 ²⁾	340 ²⁾	340 ²⁾	340 ²⁾	1.8	
	1.9	Wheelbase y (mm)	1249	1249	1357	1465	1357	1465	1465	1.9	
	Weights	2.1	Service weight incl. battery (see line 6.5)	kg	2733	2978	3000	3057	3256	3207	3382
2.2		Axle loading, laden front/rear	kg	3545/488	3870/608	4052/548	4060/597	4380/675	4405/602	4706/676	2.2
2.3		Axle loading, unladen front/rear	kg	1326/1407	1310/1668	1411/1589	1496/1561	1409/1846	1520/1686	1501/1881	2.3
Wheels, Chassis	3.1	Tyres	SE(L)/SE(L)	SE(L)/SE(L)	SE(L)/SE(L)	SE(L)/SE(L)	SE/SE	SE/SE	SE/SE	3.1	
	3.2	Tyre size, front	18x7-8	18x7-8	18x7-8	18x7-8	200/50-10	200/50-10	200/50-10	3.2	
	3.3	Tyre size, rear	140/55-9	140/55-9	140/55-9	140/55-9	140/55-9	140/55-9	140/55-9	3.3	
	3.5	Wheels, number front rear (x = driven wheels)	2x/2	2x/2	2x/2	2x/2	2x/2	2x/2	2x/2	3.5	
	3.6	Tread, front b ₁₀ (mm)	904	904	904	904	914	914	914	3.6	
	3.7	Tread, rear b ₁₁ (mm)	176	176	176	176	176	176	176	3.7	
	Basic Dimensions	4.1	Tilt of mast/fork carriage forward/backward α/β(°)	7/7	7/7	7/7	7/7	7/7	7/7	7/7	4.1
4.2		Closed mast height h ₁ (mm)	2000	2000	2000	2000	2000	2000	2000	4.2	
4.3		Free lift h ₂ (mm)	150	150	150	150	150	150	150	4.3	
4.4		Lift h ₃ (mm)	3000	3000	3000	3000	3000	3000	3000	4.4	
4.5		Height, mast extended h ₄ (mm)	3560	3560	3560	3560	3587	3587	3587	4.5	
4.7		Height of overhead guard (cabin) h ₆ (mm)	2040	2040	2040	2040	2040	2040	2040	4.7	
4.8		Seat height/stand height h ₇ (mm)	920	920	920	920	920	920	920	4.8	
4.12		Coupling height h ₁₀ (mm)	560	560	560	560	560	560	560	4.12	
4.19		Overall length l ₁ (mm)	2924	2924	3037	3145	3037	3145	3145	4.19	
4.20		Length to face of forks l ₂ (mm)	1774	1774	1887	1995	1887	1995	1995	4.20	
4.21		Overall width b ₁ /b ₂ (mm)	1060/-	1060/-	1060/-	1060/-	1120/-	1120/-	1120/-	4.21	
4.22		Fork dimensions s/e/l (mm)	35/100/1150	35/100/1150	40/100/1150	40/100/1150	40/100/1150	40/100/1150	40/100/1150	4.22	
4.23		Fork carriage ISO 2328, class/type A, B	2A	2A	2A	2A	2A	2A	2A	4.23	
4.24		Fork-carriage width b ₃ (mm)	980	980	980	980	980	980	980	4.24	
4.31		Ground clearance, laden, below mast m ₁ (mm)	80	80	80	80	80	80	80	4.31	
4.32	Ground clearance, centre of wheelbase m ₂ (mm)	100	100	100	100	100	100	100	4.32		
4.33	Aisle width for pallets 1000x1200 crossways Ast (mm)	3104	3104	3216	3323	3216	3323	3323	4.33		
4.34	Aisle width for pallets 800x1200 lengthways Ast (mm)	3226	3226	3339	3446	3339	3446	3446	4.34		
4.35	Turning radius Wa (mm)	1440	1440	1548	1655	1548	1655	1655	4.35		
Performance Data	5.1	Travel speed, laden/unladen	km/h	16/16	16/16	16/16	16/16	16/16	16/16	5.1	
	5.2	Lift speed, laden/unladen	m/s	0.48/0.60	0.46/0.60	0.49/0.60	0.49/0.60	0.44/0.55	0.44/0.55	0.40/0.55	5.2
	5.3	Lowering speed, laden/unladen	m/s	0.55/0.55	0.55/0.55	0.55/0.55	0.55/0.55	0.55/0.55	0.55/0.55	0.55/0.55	5.3
	5.5	Drawbar pull, laden/unladen S ₂ 60 min.	N	2300/2500	2200/2450	2150/2450	2100/2450	2000/2300	2000/2300	1900/2300	5.5
	5.6	Max. drawbar pull, laden/unladen S ₂ 5 min.	N	12700/12700	12700/12700	12700/12700	12700/12700	12400/12200	12400/12200	12300/12000	5.6
	5.7	Gradeability, laden/unladen S ₂ 30 min.	%	7.6/12.5	7.3/12.3	7.3/12.3	7.0/11.5	6.2/10.7	5.9/10.5	5.7/10.4	5.7
	5.8	Max. gradeability, laden/unladen S ₂ 5 min.	%	28/35	27/35	27/35	27/35	26/35	25/35	24/35	5.8
	5.9	Acceleration time, laden/unladen	s	3.6/3.2	3.8/3.4	3.8/3.4	3.8/3.4	3.9/3.5	3.9/3.5	4.0/3.5	5.9
	5.10	Service brake		electr./mech.	electr./mech.	electr./mech.	electr./mech.	electr./mech.	electr./mech.	electr./mech.	5.10
	E-Motor	6.1	Drive motor rating S ₂ 60 min.	kW	4.5/4.5	4.5/4.5	4.5/4.5	4.5/4.5	4.5/4.5	4.5/4.5	4.5/4.5
6.2		Lift motor rating at S ₃ 15 %	kW	11.5	11.5	11.5	11.5	11.5	11.5	11.5	6.2
6.3		Battery acc. to DIN 43531/35/36 A, B, C, no		DIN 43531 A	DIN 43531 A	DIN 43531 A	DIN 43531 A	DIN 43531 A	DIN 43531 A	DIN 43531 A	6.3
6.4		Battery voltage, nominal capacity K _s	V/Ah	48/500	48/500	48/625	48/750	48/625	48/750	48/750	6.4
6.5		Battery weight	kg	715	715	855	1025	855	1025	1025	6.5
6.6		Battery dimensions l/w/h	mm	830/522/627	830/522/627	830/630/627	830/738/627	830/630/627	830/738/627	830/738/627	6.5
	Energy consumption acc. to VDI cycle	kWh/h	4.2 ³⁾	4.3 ³⁾	4.3 ³⁾	4.4 ³⁾	4.7 ³⁾	4.7 ³⁾	4.9 ³⁾	6.6	
Others	8.1	Type of drive control		impulse/AC	impulse/AC	impulse/AC	impulse/AC	impulse/AC	impulse/AC	impulse/AC	8.1
	8.2	Operating pressure for attachments	bar	200	200	200	200	200	200	200	8.2
	8.3	Oil volume for attachments	l/min	25	25	25	25	25	25	25	8.3
	8.4	Sound level at the driver's ear according to EN 12053	dB (A)	66	66	66	66	66	66	66	8.4
	8.5	Towing coupling, type DIN		DIN 15170/H	DIN 15170/H	DIN 15170/H	DIN 15170/H	DIN 15170/H	DIN 15170/H	DIN 15170/H	8.5

1) = 360 mm with DZ mast; with integrated sideshift: x = 358 mm (383 mm with DZ mast); with sideshift attachment: x = 395 mm (420 mm with DZ mast)
 2) = 365 mm with DZ mast; with integrated sideshift: x = 363 mm (388 mm with DZ mast); with sideshift attachment: x = 400 mm (425 mm with DZ mast)
 3) 60 working cycles/h, tolerance +/- 10% possible

Make use of the advantages

Superior operator problem

The ergonomically designed operator's cab allows for relaxed operation with low fatigue, even during long shifts:

- Light and effortless electric steering, reduces the number of steering wheel turns and a smaller steering wheel.
- The elimination of hydraulic components in the leg area reduces steering-related noise and provides more legroom.
- The height and pitch of the steering column is adjustable.
- All essential controls are located on the adjustable armrests (adjustable height and length), making operation especially comfortable.
- Minimal vibration due to the decoupling of the cabin from the chassis ("Floating Cab").
- Clearly arranged operator display.

Professional battery management

AC technology offers both improved efficiency as well as delete energy reclamation, for longer operation time between battery changes.

- Sideways battery access.
- Individual charging systems with hand pallet truck, forktruck or crane.
- Simple, space-saving charging through side door.
- Easy access for maintenance.
- OnBoard charger with 2 charging periods – 8 or 12 hour for more flexibility and shorter charging time compared to the standard charger.

Maintenance-free braking system

Three maintenance-free braking systems make braking safe and comfortable:

- Motor brake for regenerative braking during deceleration.
- Automatically engaging parking brake for secure stopping, even on ramps.



SOLO-PILOT

- Brake pedal operated, maintenance-free disc brakes during dangerous situations.

Maintenance-free motors

The new generation of three-phase AC motors will impress you with their quiet and precise operation at all speeds.

- High torque for faster operation cycles.
- Lifetime lubrication of main components.
- Individually mounted drive motors for simpler servicing.
- Dust and water jet protection to IP 54.

Safety systems

High performance also requires a high degree of safety. That's why the EFG Series 2 includes a comprehensive range of safety equipment:

- Deactivation of hydraulic functions when the operator seat is not occupied.
- No roll-back on ramps or inclines with the automatic parking brake, even when the vehicle is switched off.
- Automatic reduction of the driving speed during cornering, with Jungheinrich Curve Control.
- Speedometer.

A range of driver assistance systems (optional) offer additional safety for the driver, truck and load:



MULTI-PILOT

- Access Control: the access control system unlocks the vehicle only after a sequence of safety checks:
 1. Valid access code/activation of key switch.
 2. Operation of the seat switch (operator in seat).
 3. Seatbelt is secured.
- Drive Control: automatically reduces the travel speed during cornering and at defined lift heights.
- Lift Control: controls the speed of lift and automatically reduces the tilt speed of the mast at defined lift heights. The tilt is shown on a separate display. An integrated sideshift (optional) can be automatically centralized at the push of a button.

Intelligent electronics

- Jerk-free travel, smooth reversing and precise positioning.
- Optimally adapted to any situation using 5 individual work programmes.
- The monitoring of all components and saving of service data, allowing fast and low cost maintenance routines using the diagnosis system.
- Standard display of the steering wheel position and the travel speed.

Jungheinrich UK Ltd.

Head Office:

Sherbourne House · Sherbourne Drive
Tilbrook · Milton Keynes MK7 8HX
Phone 01908 363100
Fax 01908 363180

info@jungheinrich.co.uk
www.jungheinrich.co.uk

Jungheinrich AG
ISO 9001, ISO 14001
Certification of Quality and
Environment Management.



Jungheinrich trucks
conform to the European
Safety Requirements.



JUNGHEINRICH
Well worthwhile