

**High performance electric forklift
with enclosed front wheel
AC motor drive**

5 adjustable working programs

**Jungheinrich Curve Control
for safer driving and cornering**

Automatic parking brake

Maintenance-free multiple disc brakes



EFG 535–550

Electric four-wheel forklift truck (3500, 4000, 4500 and 4990 kg)

With exceptional travel and lift speeds plus excellent acceleration and climbing ability, the EFG 535–550 achieve high throughput efficiency and fast work cycles – in inside as well as outside applications. Encapsulated motors ensure that the trucks are fully operational even in difficult environments, such as heavy dust, chemicals or moisture. This makes the EFG 535–550 suitable for any application.

Of course, there is also a contribution by the emission-free and quiet drive motor that can be integrated into any working environment.

Due to three-phase AC technology, there are many possibilities and advantages in the application of electric fork lifts:

- Excellent performance values for acceleration, travel and lift speeds allow for maximum productivity.
- Longer operating times through optimum efficiency and more effective energy regeneration.
- Precise traction control and wear-free regenerative braking with the energy being fed back into the battery on releasing the drive pedal.
- Maintenance and wear-free three-phase AC motors without brushes.

The result: faster work cycles at considerably longer operating times with one battery charge. Together with reduced service costs, this ensures high performance efficiency through low operating costs.

EFG 535–550

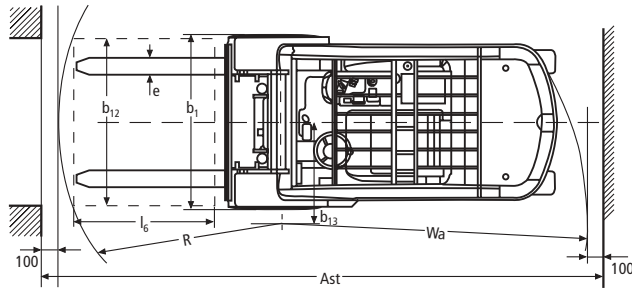
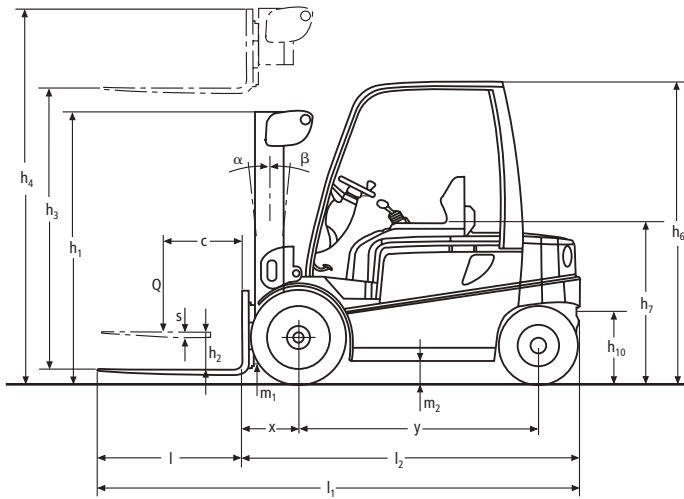

Capacity

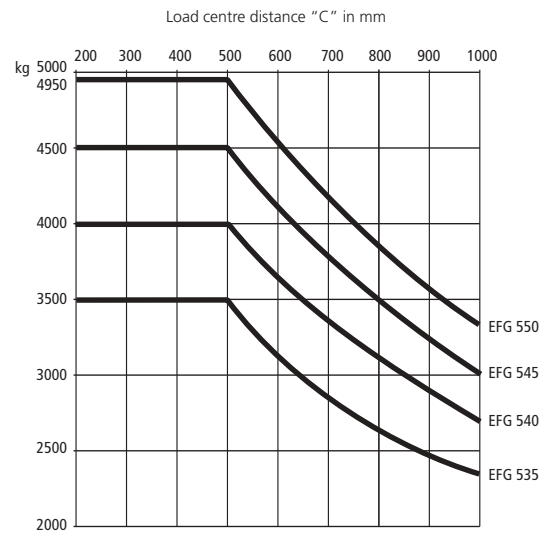

Mast table EFG 535–550										Capacity table (kg) c = 500 mm				
Designation	Lift height h ₃ mm	Free lift h ₂ mm			Closed mast height h ₁ mm		Extended mast height h ₄ mm			Tilt forward / backward α/β (°)	without sideshift, single solid tyres			
		EFG 535	EFG 540/545	EFG 550			EFG 535	EFG 540/545	EFG 550		EFG 535	EFG 540	EFG 545	EFG 550
Two-stage ZT	2750		150	150		2280		3580	3580	6/8		4000	4500	4990
	3000		150	150		2405		3830	3830	6/8		4000	4500	4990
	3100	150			2228		3883			6/8	3500			
	3500	150	150	150	2428	2655	4283	4330	4330	6/8	3500	4000	4500	4990
	4000	150	150	150	2678	2905	4783	4830	4830	6/8	3500	4000	4500	4990
	4500	150	150	150	2978	3155	5283	5330	5330	6/8	3500	4000	4500	4990
	5000	150	150	150	3228	3405	5783	5830	5830	6/5	3450	4000	4500	4950
	5500		150	150		3655		6330	6330	6/5		3850	4100	4400
Two-stage ZZ	2700		1376	1227		2080		3404	3553	6/8		4000	4500	4990
	2950		1501	1352		2205		3654	3803	6/8		4000	4500	4990
	3450		1751	1602		2455		4154	4303	6/8		4000	4500	4990
	3950		2001	1852		2705		4654	4803	6/8		4000	4500	4990
	4450		2251	2102		2955		5154	5303	6/8		4000	4500	4990
	4950		2501	2352		3205		5654	5803	6/5		4000		
	5450		2751	2602		3455		6154	6303	6/5				
Two-stage DZ	3800		1376	1227		2080		4504	4653	6/8		4000	4500	4990
	4175		1501	1352		2205		4879	5023	6/8		4000	4500	4990
	4700	1430			2193		5463			6/5	3500			
	4925		1751	1602		2455		5629	5773	6/5		3920	4420	4750
	5000	1530			2293		5763			6/5	3450			
	5300		1876	1727		2580		6004	6153	6/5		3890	4300	4700
	5500	1730			2493		6263			6/5	3100			
	5675		2001	1852		2705		6379	6523	6/5		3750	4200	4610
	6000	1930			2693		6763			6/5	2850			
	6425		2251	2102		2955		7129	7273	6/3		3580	4000	4300
	6500	2130			2893		7263			6/3	2600			
7175		2501	2352		3205		7879	8023	6/3		3200	3200	4000	

Technical Data in line with VDI 2198 as at: 09/2005

Identification	1.1	Manufacturer (abbreviation)	Jungheinrich	Jungheinrich	Jungheinrich	Jungheinrich	1.1
	1.2	Manufacturer's type designation	EFG 535	EFG 540	EFG 545	EFG 550	1.2
	1.3	Drive (electric – battery or mains, diesel, petrol, fuel gas, manual)	electric	electric	electric	electric	1.3
	1.4	Type of operation (hand, pedestrian, standing, seated, order picker)	seated	seated	seated	seated	1.4
	1.5	Load capacity/rated load Q (t)	3.5	4.0	4.5	4.99	1.5
	1.6	Load centre distance c (mm)	500	500	500	500	1.6
	1.8	Load distance, centre of drive axle to fork x (mm)	480	510	510	510	1.8
	1.9	Wheelbase y (mm)	1855	2000	2000	2000	1.9
	Weights	2.1	Service weight incl. battery (see line 6.5) kg	5800	6600	6950	7300
2.2		Axle loading, laden front/rear kg	8350/950	9700/900	10400/1050	11200/1100	2.2
2.3		Axle loading, unladen front/rear kg	3000/2800	3700/2900	3700/3250	3700/3600	2.3
Wheels, Chassis	3.1	Tyres (solid rubber, superelastic, pneumatic, polyurethane)	solid	solid	solid	solid	3.1
	3.2	Tyre size, front (∅ x width)	250-15	250-15	250-15	28 x 12.5-15	3.2
	3.3	Tyre size, rear (∅ x width)	21 x 8-9	21 x 8-9	21 x 8-9	21 x 8-9	3.3
	3.5	Wheels, number front rear (x = driven wheels)	2x/2	2x/2	2x/2	2x/2	3.5
	3.6	Track width, front b ₁₀ (mm)	1120	1120	1120	1150	3.6
	3.7	Track width, rear b ₁₁ (mm)	950	950	950	950	3.7
	Basic Dimensions	4.1	Mast/fork carriage tilt forward/backward α°/β°	6/8	6/8	6/8	6/8
4.2		Lowered mast height h ₁ (mm)	2228	2405	2405	2405	4.2
4.3		Free lift h ₂ (mm)	150	150	150	150	4.3
4.4		Lift height h ₃ (mm)	3100	3000	3000	3000	4.4
4.5		Extended mast height h ₄ (mm)	3883	3830	3830	3830	4.5
4.7		Overhead load guard (cab) height h ₆ (mm)	2320	2320	2320	2320	4.7
4.8		Seat height/standing height h ₇ (mm)	1165	1165	1165	1165	4.8
4.12		Coupling height h ₁₀ (mm)	390/550	390/550	390/550	390/550	4.12
4.19		Overall length l ₁ (mm)	3835	3980	3980	3980	4.19
4.20		Length to face of forks l ₂ (mm)	2685	2830	2830	2830	4.20
4.21		Overall width b ₁ /b ₂ (mm)	1340/–	1340/–	1340/–	1450/–	4.21
4.22		Fork dimensions s/e/l (mm)	45 x 125 x 1150	50 x 125 x 1150	50 x 150 x 1150	50 x 150 x 1150	4.22
4.23		Fork carriage ISO 2328, class/type A, B	3 A	3 A	3 A	3 A	4.23
4.24		Fork carriage width b ₃ (mm)	1120	1260	1260	1260	4.24
4.31		Ground clearance, laden, under mast m ₁ (mm)	120	120	120	120	4.31
4.32		Ground clearance, centre of wheelbase m ₂ (mm)	160	160	160	160	4.32
4.33		Aisle width for pallets 1000 x 1200 crossways Ast (mm)	3980	4160	4160	4160	4.33
4.34		Aisle width for pallets 800 x 1200 lengthways Ast (mm)	4180	4360	4360	4360	4.34
4.35		Turning radius Wa (mm)	2300	2450	2450	2450	4.35
4.36	Smallest pivot point distance b ₁₃ (mm)	670	670	670	725	4.36	
Performance Data	5.1	Travel speed, laden/unladen km/h	16/17	15/17	15/16.5	15/16	5.1
	5.2	Lift speed, laden/unladen m/s	0.38/0.50	0.35/0.47	0.33/0.45	0.31/0.45	5.2
	5.3	Lowering speed, laden/unladen m/s	0.58/0.55	0.55/0.50	0.55/0.50	0.55/0.50	5.3
	5.5	Drawbar pull, laden/unladen S ₂ 60 min N	5200/5700	5100/5600	4900/5500	5000/5800	5.5
	5.6	Max. drawbar pull, laden/unladen S ₂ 5 min N	14700/14900	14600/14900	14500/14800	15100/15500	5.6
	5.7	Gradient performance, laden/unladen S ₂ 30 min %	8.5/14.5	8/13.5	7/12	6.5/12	5.7
	5.8	Max. gradient performance, laden/unladen S ₂ 5 min %	15.5/25	14/23.5	12.5/21.5	12/21	5.8
	5.9	Acceleration time, laden/unladen s	4.8/4.2	5.0/4.4	5.5/4.8	5.8/5.2	5.9
	5.10	Service brake	hydr.	hydr.	hydr.	hydr.	5.10
	E-Motor	6.1	Drive motor rating S ₂ 60 min kW	18	18	18	18
6.2		Lift motor rating at S ₃ 15 % kW	23.5	23.5	23.5	23.5	6.2
6.3		Battery acc. to DIN 43531/35/36 A, B, C, no	43536 A	43536 A	43536 A	43536 A	6.3
6.4		Battery voltage, nominal capacity K ₅ V/Ah	80/700	80/840	80/840	80/840	6.4
6.5		Battery weight kg	1863	2178	2178	2178	6.5
6.6		Battery dimensions l/w/h cm	1028/855/784	1028/999/784	1028/999/784	1028/999/784	6.6
Other Details	8.1	Type of drive control	impulse/AC	impulse/AC	impulse/AC	impulse/AC	8.1
	8.2	Operating pressure for attachments bar	200	200	200	200	8.2
	8.3	Oil volume for attachments l/min	30	30	30	30	8.3
	8.4	Sound level at driver's ear according to DIN 12 053 dB(A)	75	75	75	75	8.4
	8.5	Tow coupling, type DIN	DIN 15170 H	DIN 15170 H	DIN 15170 H	DIN 15170 H	8.5

1) 505 mm with DZ mast, with integrated sidishift: x = 494 mm (519 mm with DZ mast), with sidishift attachment: x = 552 mm (577 mm with DZ mast)

2) 541 mm with DZ mast, with integrated sidishift: x = 542 mm (573 mm with DZ mast), with sidishift attachment: x = 582 mm (613 mm with DZ mast)

3) 45 VDI working cycles/h

Make use of the advantages

Superior operator comfort

Functionality and ergonomics of the driver environment guarantees relaxed, fatigue-free work over long shifts:

- Low access step and large, level foot well with automotive pedal lay-out.
- Steering column and comfort seat allow multiple adjustments for optimum seating position.
- Floating Cab module cushions road shocks and vibrations.
- Clear view: mast and fork carriage allow for excellent visibility to load and road.
- Hydraulic power steering is precise and low effort without kick-back.



SOLO-PILOT

- Comfort Display provides up-to-date information on vital vehicle conditions at a glance.
- Comfortable, fatigue-free operation of direction and hydraulics by SOLO-PILOT or MULTI-PILOT (optional).
- Numerous storage facilities for the operators belongings, e.g. cup holder.

Safe, wear free braking – parking brake with automatic operation

Three braking systems ensure safe, precise and virtually wear-free braking:

- Regenerative electric braking in reversing mode and regular brake pedal use.



MULTI-PILOT

- Multiple oil disc brakes act as a safety back-up. Wear-free and fully enclosed.
- The parking brake is electronically operated through spring accumulation. It automatically engages when the forklift is stationary and releases again when the truck starts to drive. This way any uncontrolled rolling of the truck can be eliminated.

Maintenance-free electric motors

Drive, hydraulic pump and steering motors are consistently equipped with proven AC technology. The advantages:

- High torque for rapid work cycles.
- Up to 15 % higher energy efficiency than shunt-wound motors.
- No maintenance costs through omission of brushes and collector.
- Enclosed construction ensures long life even under dusty and damp conditions.
- 2-year warranty.

Active safety

Excellent drive dynamics and performance also demand a high degree of safety:

- Jungheinrich Curve Control automatically reduces travel speed when cornering.
- Automatic parking brake ensures controlled operation on ramps and slopes.
- Increased stability and residual capacity through very low centre of gravity.

- Long wheelbase ensures stable handling and smooth travel.
- Electronic and hydraulic overload protection guard.
- Quickly accessible emergency cut off switch.
- Reliable data transfer between electronic components through CAN-Bus technology.

Intelligent electronics



Comfort Display

BoardControl electronic system permanently controls and monitors all truck functions:

- Smooth driving, dynamic reversing and precise load positioning with a minimum of energy.
- 5 application programs can be individually adapted to ensure optimal performance in any application.
- Diagnostic system monitors all components and provides service data memory for rapid and cost-effective maintenance.
- Comfort Display with digital service hour meter, battery discharge indicator plus lift cut-out, clock, error code and warning displays.
- Electronic steer wheel position indicator.

Jungheinrich UK Ltd.

Head Office:

Sherbourne House
 Sherbourne Drive
 Tilbrook
 Milton Keynes MK7 8HX
 Telephone 01908 363100

info@jungheinrich.co.uk
 www.jungheinrich.co.uk

ISO 9001, ISO 14001
 Certification of Quality and
 Environment Management.



Jungheinrich trucks
 conform to the European
 Safety Requirements.



JUNGHEINRICH
Well worthwhile