

**48 V 3-phase AC technology
for high torques and
dynamic movement sequences**

**First-rate economic efficiency
through two-fold
energy reclamation**

**Excellent reliability through
AC power control and CAN-Bus**

**Optimised operator control
at ergonomic workplace**

**Broad application spectrum
with solution-oriented options**



EKV 410

Order picker/tri-lateral stacker (1000 kg)

The EKV 410 of the Kombi range with 48V AC technology, 1000 kg capacity and lift heights up to 7750 mm gives outstanding performance in narrow aisle warehousing. The ability to stack or retrieve whole pallets and pick individual items from the racking increases flexibility and economic performance. This high efficiency is available to the EKV operator with effortless ease: The clearly arranged cab provides a generously dimensioned workplace. Large storage areas, clear con-

tours and the choice of standing or sitting position make operation significantly more pleasant and thus faster. At the centre of the efficiency-supporting operating concept is the height and tilt adjustable operating console. With a number of innovative performance characteristics, it defines state of the art system ergonomics:

- Information transmission via graphic display. Important operating data is quickly and legibly depicted in pictograms.

- Travel and hydraulics are controlled via thumb movement.
- Two-handed operating concept first class safety and operating comfort. Switch-free sensors register the operator's touch and pass this information to the onboard computer. Here, all safety-relevant checks are carried out. The intensity of the required touch is individually adjustable.

EKX 410

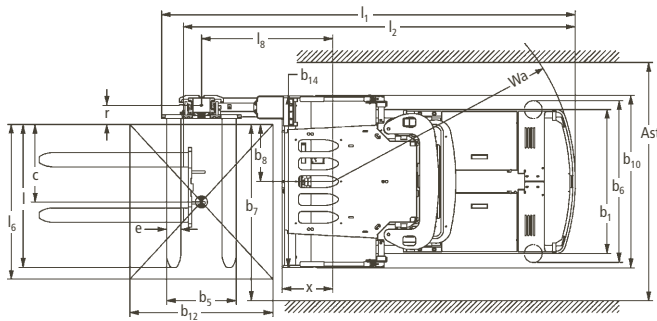
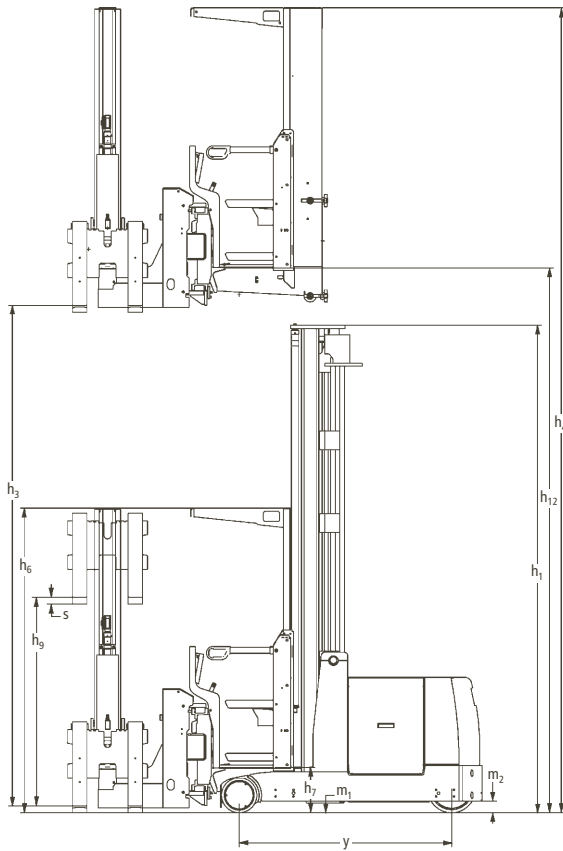

Standard values for working aisle widths (mm)				
with rail guidance				
pallet size	stacking-in depth	Ast	Ast ₃ /VDI theoretical	Ast ₃ * practical
1200 x 800	1200	1640	3760	+500
1200 x 1200	1200	1640	4080	+500
800 x 1200	800	1350	3998	+500

* the practical transfer aisle width is a reference value

with inductive guidance				
pallet size	stacking-in depth	Ast	Ast ₃ /VDI theoretical	Ast ₃ * practical
1200 x 800	1200	1720	3770	+1000
1200 x 1200	1200	1720	4088	+1000
800 x 1200	800	1400	4007	+1000

* the practical transfer aisle width is a reference value

Lift height table EKX 410						
Designation	Lift height h_3 mm	Total lift $h_{ges.} (h_3+h_9)$ mm	Standing height raised h_{12} mm	Order picking height h_{15} mm	Closed mast height h_1 mm	Extended mast height h_4 mm
Two-stage ZT	2500	4250	2895	4495	2550	5050
	2750	4500	3145	4745	2550	5300
	3000	4750	3395	4995	2600	5550
	3250	5000	3645	5245	2725	5800
	3500	5250	3895	5495	2850	6050
	3750	5500	4145	5745	2975	6300
	4000	5750	4395	5995	3100	6550
	4250	6000	4645	6245	3225	6800
	4500	6250	4895	6495	3350	7050
	4750	6500	5145	6745	3475	7300
	5000	6750	5395	6995	3600	7550
	5250	7000	5645	7245	3725	7800
	5500	7250	5895	7495	3850	8050
	5750	7500	6145	7745	3975	8300
6000	7750	6395	7995	4100	8550	

Technical Data in line with VDI 2198 as at: 10/2009

Identification	1.1	Manufacturer (abbreviation)	Jungheinrich	1.1
	1.2	Manufacturer's type designation	EKX 410	1.2
	1.3	Drive	electric	1.3
	1.4	Type of operation	order picker / tri-lateral stacker	1.4
	1.5	Load capacity / rated load	Q (t) 1.0	1.5
	1.6	Load centre distance	c (mm) 600	1.6
	1.8	Load distance, centre of drive axle to fork	x (mm) 428	1.8
	1.9	Wheelbase	y (mm) 1780	1.9
	Weights	2.1	Service weight incl. battery (see line 6.5)	kg 5218
2.2		Axle loading, laden front/rear	kg 4811 / 1407	2.2
2.3		Axle loading, unladen front/rear	kg 3168 / 2050	2.3
Wheels, Chassis	3.1	Tyres	Vulkollan®	3.1
	3.2	Tyre size, front	295 x 144	3.2
	3.3	Tyre size, rear	343 x 140	3.3
	3.5	Wheels, number front/rear (x = driven wheels)	2 / 1x	3.5
	3.6	Track width, front	b ₁₀ (mm) 1296	3.6
	3.7	Track width, rear	b ₁₁ (mm) –	3.7
	Basic Dimensions	4.2	Lowered mast height	h ₁ (mm) 3100
4.3		Free lift	h ₂ (mm) –	4.3
4.4		Lift height	h ₃ (mm) 4000 ¹⁾	4.4
4.5		Extended mast height	h ₄ (mm) 6550	4.5
4.7		Overhead load guard (cab) height	h ₆ (mm) 2550	4.7
4.8		Seat height/standing height	h ₇ (mm) 395	4.8
4.11		Additional lift	h ₉ (mm) 1750	4.11
4.14		Standing height, elevated	h ₁₂ (mm) 4395	4.14
4.19		Overall length (without load)	l ₁ (mm) 3577	4.19
4.20		Length to face of forks	l ₂ (mm) 3273	4.20
4.21		Overall width	b ₁ /b ₂ (mm) 1210 / 1450	4.21
4.22		Fork dimensions	s/e/l (mm) 40 x 120 x 1200	4.22
4.23		Fork carriage ISO 2328, class/type A, B	2 / A	4.23
4.24		Fork carriage width	b ₃ (mm) 880	4.24
4.25		Width over forks	b ₅ (mm) 793	4.25
4.27		Width across guide roller	b ₆ (mm) 1620	4.27
4.29		Reach, lateral	b ₇ (mm) 1295	4.29
4.30		Reach, lateral from vehicle centreline	b ₈ (mm) 490	4.30
4.31		Ground clearance, laden, under mast	m ₁ (mm) 75	4.31
4.32		Ground clearance, centre of wheelbase	m ₂ (mm) 80	4.32
4.33		Aisle width for pallets 1200 x 1200	Ast (mm) 1640	4.33
4.35		Turning radius	Wa (mm) 2035	4.35
4.38		Distance to swivelling forks pivot point	l ₈ (mm) 1103	4.38
4.39		Total lift	h ₃ + h ₉ (mm) 5750	4.39
4.40		Order picking height	h ₁₂ + 1600 (mm) 5995	4.40
4.41		Distance swivelling forks pivot point – steering rack	l _{9-x} (mm) 675	4.41
4.42		Pallet width	b ₁₂ (mm) 1200	4.42
4.43		Pallet length	l ₆ (mm) 1200	4.43
4.44		Clear width driver compartment entrance	(mm) 450	4.44
4.45		Clear driver compartment height inside	(mm) 2140	4.45
4.46		Driver compartment width outside	b ₉ (mm) 1440	4.46
4.47		Width swivelling reach frame	b ₁₄ (mm) 1440	4.47
4.48	Width extension arm	l ₁₀ (mm) 190	4.48	
4.49	Distance swivelling forks pivot point – fork carriage	r (mm) 136	4.49	
Performance Data	5.1	Travel speed, laden/unladen (SF)	km/h 9	5.1
	5.2	Lift speed, laden/unladen	m/s 0.36 / 0.40	5.2
	5.3	Lowering speed, laden/unladen	m/s 0.40 / 0.40	5.3
	5.4	Reach speed, laden/unladen	m/s 0.25 / 0.25	5.4
	5.10	Service brake	reverse current / regenerative	5.10
	5.11	Parking brake	electric spring loaded	5.11
Electric Engine	6.1	Drive motor rating S ₂ 60 min.	kW 4.4	6.1
	6.2	Lift motor rating at S ₂ 25 %	kW 9.5	6.2
	6.3	Battery acc. to DIN 43531 / 35 / 36 A, B, C, no	6 EPzS 690	6.3
	6.4	Battery voltage, nominal capacity K ₅	V/Ah 48 / 690	6.4
	6.5	Battery weight	kg 1011	6.5
Others	8.1	Type of drive control	AC power control	8.1
	8.4	Sound level at driver's ear according to EN 12 053	dB (A) 61	8.4
	8.6	Steering	electric	8.6

1) ZT performance data measured for 400 ZT – values according to performance specification (within 10 % tolerance of measured values)

This specification sheet according to VDI regulation 2198 only provides technical values for the standard truck. Non-standard tyres, different masts, additional equipment, etc. could produce other values. Right reserved for technical changes and improvements.

Make use of the advantages

48 V 3-phase AC technology

Constant application of 3-phase AC technology for travel, hydraulics and steering drive are characteristic of the EKV 410. The advantages are obvious:

- Optimum energy consumption through particularly favourable efficiency factor.
- High efficiency factor of hydraulic system through speed control of hydraulic motor.
- Optimised thermal economy allows the use of corrosion-free, heat-resistant plastic containers for hydraulic oil.
- High efficiency factor for motors.
- Dynamic movement sequences.
- Reduced maintenance through omission of components susceptible to wear.

Economic efficiency

During lowering of the mast, energy is fed back into the battery – the “regenerative lowering”. Energy is also fed back into the battery during braking – the “regenerative braking”. Energy reclaimed in this way is additionally available for the next energy consumption. The advantages:

- Prolonged operating times with the same battery capacity.
- Improved order picking efficiency.
- Shorter battery charging times with prolonged battery life at the same time.
- Lower investments for smaller batteries and reduced energy costs.



operating panel

Reliability

AC power control and CAN-Bus make the EKV 410 application as requirement-oriented, economical and reliable as never before. The advantages:

- Individual adjustment to every application.
- Active safety through steplessly adjustable speed profiles in narrow aisles and on aprons.
- Good care of components.
- Service-friendly through repairable boards and exchangeable interface.

Standard equipment

- Ergonomic operator cab with overhead load guard.
- Sprung, height-adjustable and foldable seat.

- Compact operating panel with graphic display, battery discharge monitor, operating hour meter, key switch, emergency stop switch, clock, display of lift height and steering position.
- Macrolon disk between upper edge of swivelling reach and parapet.
- Spring clip on rear panel.
- Fold out bottle holder.
- Electric power-assisted steering.
- Travel direction independent diagonal travel speed profiles.
- AC power control with CAN-Bus connection.
- Wear-free regenerative braking with energy reclamation.
- Spring-loaded brake on drive wheel.
- Stepless speed regulation of hydraulic aggregate.
- End position and transfer cushioning of all hydraulic functions.
- Simultaneous lowering of main and additional lift.
- Overriding rotation/reach cycle.
- Integrated diagnostic system.
- Removable rear cover for excellent accessibility.
- Foldable battery cover.
- Warning flashing light during lowering and travel operation.
- Deadman switch.
- Emergency lowering of main lift under rear cover.
- Slack chain device.



battery cover

Jungheinrich UK Ltd.

Head Office:

Sherbourne House · Sherbourne Drive
Tilbrook · Milton Keynes MK7 8HX
Phone 01908 363100
Fax 01908 363180

info@jungheinrich.co.uk
www.jungheinrich.co.uk



JUNGHEINRICH
Well worthwhile